

First laws of compact binary mechanics

Alexandre Le Tiec

Laboratoire Univers et Théories
Observatoire de Paris / CNRS

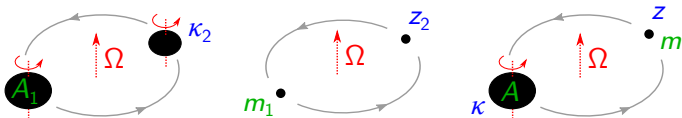

The black hole uniqueness theorem in GR

[Israel 1967, Carter 1971, Hawking 1973, Robinson 1975]

- The **only** stationary vacuum black hole solution is the Kerr solution of mass M and angular momentum S

“Black holes have no hair.” (J. A. Wheeler)

- Black hole **event horizon** \mathcal{H} characterized by:

- Angular velocity ω_H
- Surface gravity κ
- Surface area A

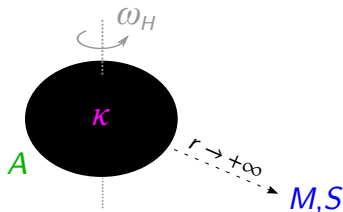

The laws of black hole mechanics

[Hawking 1972, Bardeen, Carter & Hawking 1973]

- Zeroth law of mechanics:

$$\kappa = \text{const. (on } \mathcal{H}\text{)}$$

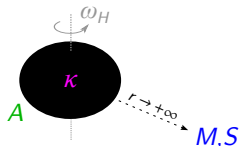

- First law of mechanics:

$$\delta M = \omega_H \delta S + \frac{\kappa}{8\pi} \delta A$$

- Second law of mechanics:

$$\delta A \geq 0$$

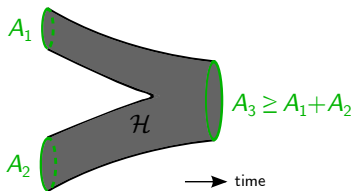

What is the horizon surface gravity?



What is the horizon surface gravity?



- For an event horizon \mathcal{H} generated by a Killing field k^α :

$$\kappa^2 \equiv \frac{1}{2} (\nabla^\alpha k^\beta \nabla_\beta k_\alpha)|_{\mathcal{H}}$$

What is the horizon surface gravity?



- For an event horizon \mathcal{H} generated by a Killing field k^α :

$$\kappa^2 \equiv \frac{1}{2} (\nabla^\alpha k^\beta \nabla_\beta k_\alpha) |_{\mathcal{H}}$$

- For a Schwarzschild black hole of mass M , this yields

$$\kappa = \frac{1}{4M} = \frac{GM}{R_S^2}$$

Beyond stationary, isolated black holes

Why?

- Astrophysical black holes are neither perfectly isolated, nor strictly stationary
- Of special interest are black holes that **interact gravitationally** with a companion in a compact binary system

Beyond stationary, isolated black holes

Why?

- Astrophysical black holes are neither perfectly isolated, nor strictly stationary
- Of special interest are black holes that **interact gravitationally** with a companion in a compact binary system

How?

- Isolated, slowly evolving, or dynamical horizons (quasi-local)
- Physical setup that guarantees the existence of an **isometry**
- **Perturbative** treatment of the problem: large separation, large mass ratio, weak tidal environment

Beyond stationary, isolated black holes

Why?

- Astrophysical black holes are neither perfectly isolated, nor strictly stationary
- Of special interest are black holes that **interact gravitationally** with a companion in a compact binary system

How?

- Isolated, slowly evolving, or dynamical horizons (quasi-local)
- ✓ Physical setup that guarantees the existence of an **isometry**
- ✓ **Perturbative** treatment of the problem: large separation, large mass ratio, weak tidal environment

Outline

- ① Circular-orbit binaries: geometrical methods
- ② Beyond circular motion: Hamiltonian methods
- ③ Applications of the first law of binary mechanics

Outline

- ① Circular-orbit binaries: geometrical methods
- ② Beyond circular motion: Hamiltonian methods
- ③ Applications of the first law of binary mechanics

Zeroth law of binary black hole mechanics

[Friedman, Uryū & Shibata 2002]

- **Black hole** spacetimes with *helical* Killing vector field k^α
- On each component \mathcal{H}_a of the event horizon, the **expansion** and **shear** of the generators vanish
- Generalized rigidity theorem:
 $\mathcal{H} = \bigcup_a \mathcal{H}_a$ is a **Killing horizon**
- *Constant* horizon **surface gravity**

$$\kappa_a^2 = \frac{1}{2}(\nabla^\alpha k^\beta \nabla_\beta k_\alpha)|_{\mathcal{H}_a}$$

- The binary black hole system is in a state of *corotation*

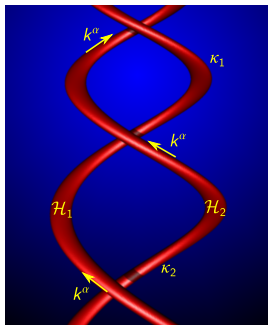

First laws of compact binary mechanics

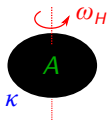

$$\delta M - \omega_H \delta S = \frac{\kappa}{8\pi} \delta A$$

[Bardeen *et al.* 1973]

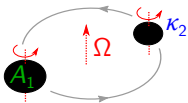

$$\delta M - \Omega \delta J = \sum_a \frac{\kappa_a}{8\pi} \delta A_a$$

[Friedman *et al.* 2002]

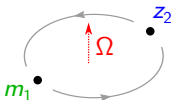

$$\delta M - \Omega \delta J = \sum_a z_a \delta m_a$$

[Le Tiec *et al.* 2012]

[Blanchet *et al.* 2013]

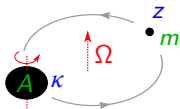

$$\delta M - \Omega \delta J = \frac{\kappa}{8\pi} \delta A + z \delta m$$

[Gralla & Le Tiec 2013]

First laws of compact binary mechanics

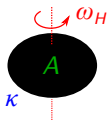

$$\delta M - \omega_H \delta S = 4\mu\kappa \delta\mu$$

[Bardeen *et al.* 1973]

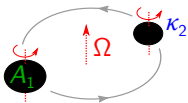

$$\delta M - \Omega \delta J = \sum_a 4\mu_a \kappa_a \delta\mu_a$$

[Friedman *et al.* 2002]

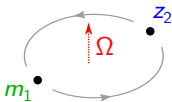

$$\delta M - \Omega \delta J = \sum_a z_a \delta m_a$$

[Le Tiec *et al.* 2012]
[Blanchet *et al.* 2013]

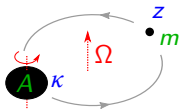

$$\delta M - \Omega \delta J = 4\mu\kappa \delta\mu + z \delta m$$

[Gralla & Le Tiec 2013]

Surface gravity and redshift variable

[Pound 2015]

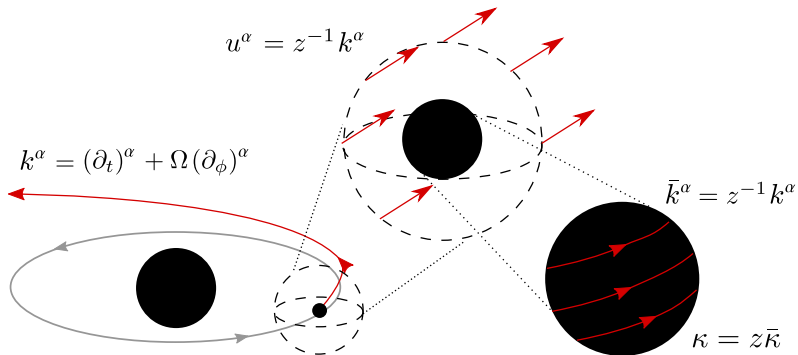

(Credit: Zimmerman, Lewis & Pfeiffer 2016)

Surface gravity vs orbital frequency

[Le Tiec & Grandclément 2018]

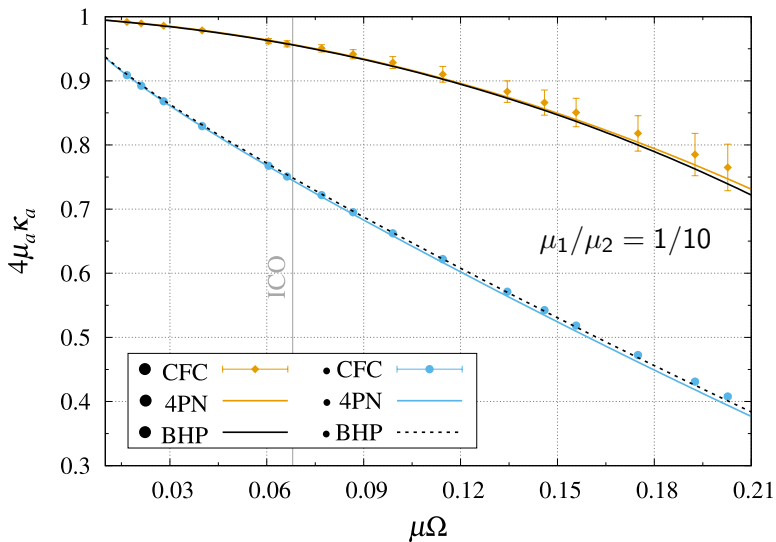

Surface gravity vs orbital frequency

[Le Tiec & Grandclément 2018]

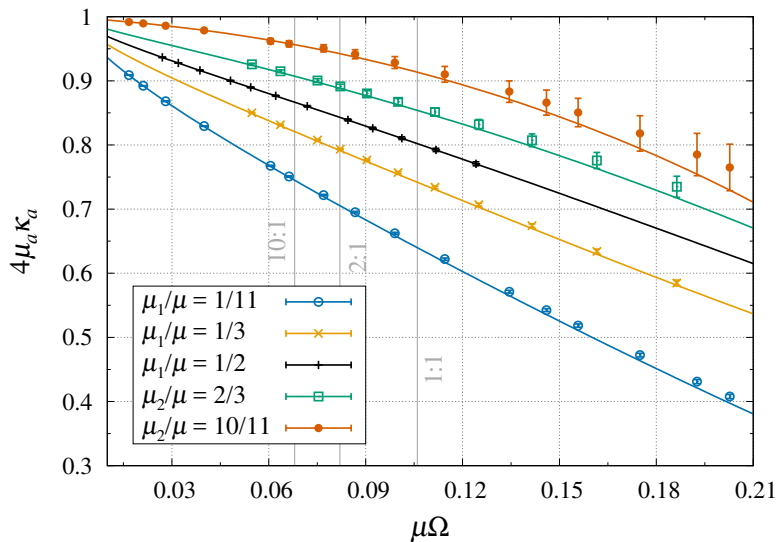

Perturbation theory for comparable masses

$$q \equiv \frac{m_1}{m_2} \rightarrow \nu \equiv \frac{m_1 m_2}{m^2}$$

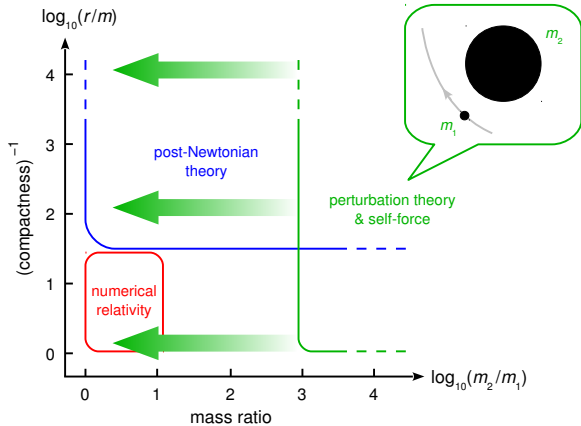

Perturbation theory for comparable masses

Relativistic orbital dynamics

- Periastron advance [Le Tiec *et al.* 2011; 2013]
- Binding energy [Le Tiec, Buonanno & Barausse 2012]
- Surface gravity [Zimmerman *et al.* 2016; Le Tiec & Grandclément 2018]

Gravitational-wave emission

- Recoil velocity [Fitchett & Detweiler 1984; Nagar 2013]
- Head-on waveform [Anninos *et al.* 1995; Sperhake *et al.* 2011]
- Inspiral phasing [van de Meent & Pfeiffer 2020; Wardell *et al.* 2021]
- Inspiral energy flux [Warburton *et al.* 2021]

Perturbation theory for comparable masses

[van de Meent & Pfeiffer 2020]

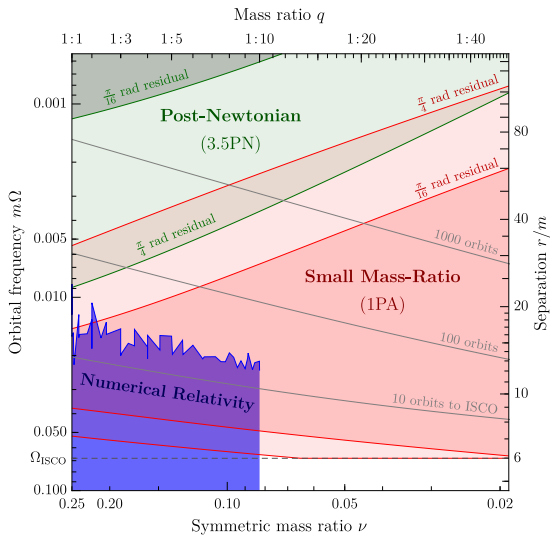

$$q = m_1/m_2$$

↓

$$\nu = m_1 m_2 / m^2$$

Multipolar gravitational skeleton

[Mathisson 1937; Tulczyjew 1957]

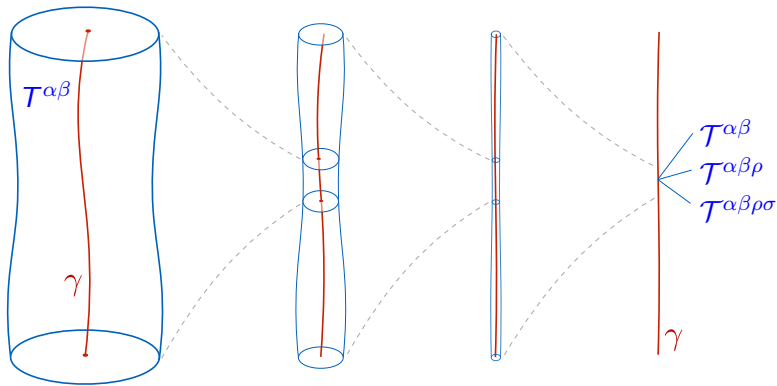

$$T^{\alpha\beta} \rightarrow T_{\text{skel}}^{\alpha\beta} = \int_{\gamma} d\tau \left[\underbrace{T^{\alpha\beta} \delta_4}_{\text{monopole}} + \underbrace{\nabla_{\rho} (T^{\alpha\beta\rho} \delta_4)}_{\text{dipole}} + \dots \right]$$

Multipolar gravitational skeleton

[Mathisson 1937; Tulczyjew 1957]

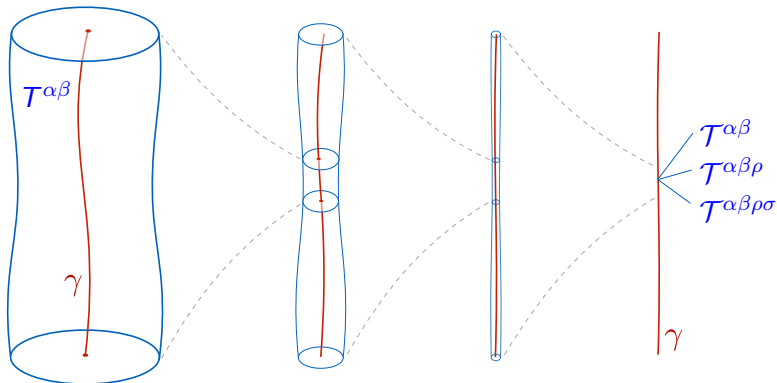

$$T^{\alpha\beta} \rightarrow T_{\text{skel}}^{\alpha\beta} = \int_{\gamma} d\tau \left[\underbrace{u^{(\alpha} p^{\beta)}}_{\text{monopole}} \delta_4 + \underbrace{\nabla_{\rho} (u^{(\alpha} S^{\beta)\rho}}}_{\text{dipole}} \delta_4 + \dots \right]$$

Quadrupolar particles on a circular orbit

[Ramond & Le Tiec 2022]

- Helical Killing field k^α so that

$$\mathcal{L}_k g_{\alpha\beta} = 0$$

- Each particle worldline γ is an integral curve of k^α :

$$k^\alpha|_\gamma = z u^\alpha$$

- The particle multipoles are all Lie-dragged along k^α :

$$\mathcal{L}_k p^\alpha = \mathcal{L}_k S^{\alpha\beta} = \mathcal{L}_k Q^{\alpha\beta\rho\sigma} = 0$$

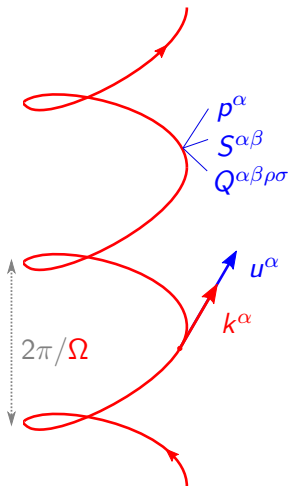

First law with finite-size effects

[Ramond & Le Tiec 2022]

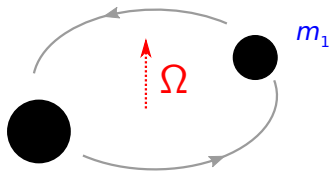

$$\delta M - \Omega \delta J = \sum_a |k|_a \delta m_a$$

First law with finite-size effects

[Ramond & Le Tiec 2022]

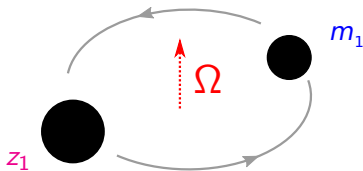

$$\delta M - \Omega \delta J = \sum_a z_a \delta m_a$$

First law with finite-size effects

[Ramond & Le Tiec 2022]

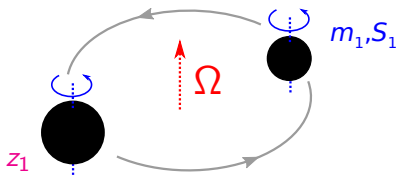

$$\delta M - \Omega \delta J = \sum_a z_a \delta m_a - \sum_a |\nabla k|_a \delta S_a$$

First law with finite-size effects

[Ramond & Le Tiec 2022]

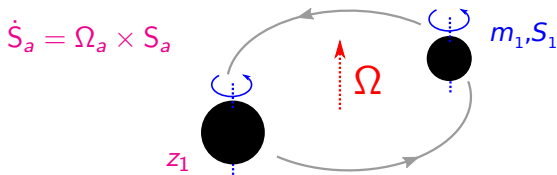

$$\dot{S}_a = \Omega_a \times S_a$$

$$\delta M - \Omega \delta J = \sum_a z_a \delta m_a - \sum_a (\Omega - \Omega_a) \delta S_a$$

First law with finite-size effects

[Ramond & Le Tiec 2022]

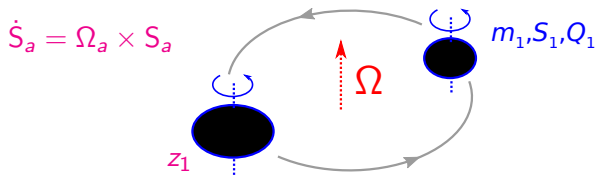

$$\delta M - \Omega \delta J = \sum_a z_a \delta m_a - \sum_a (\Omega - \Omega_a) \delta S_a + \sum_a |\nabla \nabla k|_a \delta Q_a$$

First law with finite-size effects

[Ramond & Le Tiec 2022]

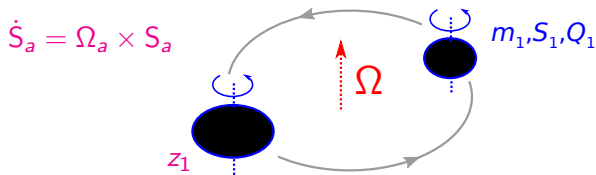

$$\delta M - \Omega \delta J = \sum_a z_a \delta m_a - \sum_a (\Omega - \Omega_a) \delta S_a + \sum_a \mathcal{E}_a \delta Q_a$$

First law with finite-size effects

[Ramond & Le Tiec 2022]

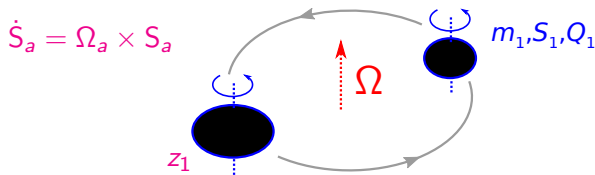

$$\delta M - \Omega \delta J = \sum_a z_a \delta m_a - \sum_a (\Omega - \Omega_a) \delta S_a + \sum_a \mathcal{E}_a \delta Q_a$$

- Spin-induced quadrupole $Q_{\text{spin}} \sim \kappa S^2$
- Tidally-induced quadrupole $Q_{\text{tidal}} \sim \lambda \mathcal{E}$

Tidal deformability of Kerr black holes

[Le Tiec, Casals & Franzin 2021]



$$Q_{ij}^{\text{spin}} = -S_{\langle i} S_{j \rangle} / M \quad \text{and} \quad Q_{ij}^{\text{tidal}} = \frac{16}{45} M^3 \mathcal{E}^k_{(i} \epsilon_{j)kl} S^l$$

Consistent with known **tidal torquing** of spinning black holes

Outline

- ① Circular-orbit binaries: geometrical methods
- ② Beyond circular motion: Hamiltonian methods
- ③ Applications of the first law of binary mechanics

Averaged redshift for eccentric orbits

[Barack & Sago 2011]

- Generic eccentric orbit parameterized by the two frequencies

$$\Omega_r = \frac{2\pi}{P}, \quad \Omega_\phi = \frac{\Phi}{P}$$

- Time average of redshift $z = d\tau/dt$ over one radial period

$$\langle z \rangle \equiv \frac{1}{P} \int_0^P z(t) dt = \frac{1}{P} \int_0^{\mathcal{T}} d\tau = \frac{\mathcal{T}}{P}$$

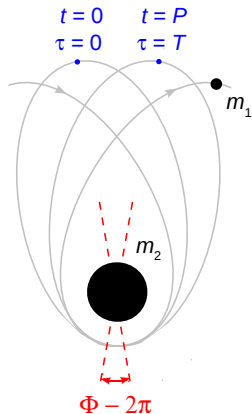

First law of mechanics for eccentric orbits

[Le Tiec 2015; Blanchet & Le Tiec 2017]

- Canonical ADM Hamiltonian $H(x_a, p_a; m_a)$ of two point particles with constant masses m_a
- Variation δH + Hamilton's equation + orbital averaging:

$$\delta M = \Omega_\phi \delta L + \Omega_r \delta J_r + \sum_a \langle z_a \rangle \delta m_a$$

- Starting at **4PN order** the binary dynamics gets **nonlocal in time** because of gravitational-wave **tails**:

$$H_{\text{tail}}^{\text{4PN}}[x_a(t), p_a(t)] = -\frac{M}{5} I_{ij}^{(3)}(t) \text{Pf}_{2r} \int_{-\infty}^{+\infty} \frac{d\tau}{\tau} I_{ij}^{(3)}(t + \tau)$$

- With appropriate M , L and J_r the first law still holds

Particle Hamiltonian first law

- Geodesic motion of test mass m in Kerr geometry $\bar{g}_{\alpha\beta}$ derives from **Hamiltonian**

$$\bar{H}(x, p) = \frac{1}{2} \bar{g}^{\alpha\beta}(x^\mu) p_\alpha p_\beta$$

Particle Hamiltonian first law

- Geodesic motion of test mass m in Kerr geometry $\bar{g}_{\alpha\beta}$ derives from **Hamiltonian**

$$\bar{H}(x, p) = \frac{1}{2} \bar{g}^{\alpha\beta}(x^\mu) p_\alpha p_\beta$$

- Hamilton-Jacobi equation is completely separable [Carter 1968]

Particle Hamiltonian first law

- Geodesic motion of **test mass** m in Kerr geometry $\bar{g}_{\alpha\beta}$ derives from **Hamiltonian**

$$\bar{H}(x, p) = \frac{1}{2} \bar{g}^{\alpha\beta}(x^\mu) p_\alpha p_\beta$$

- Hamilton-Jacobi equation is completely separable [Carter 1968]
- Canonical transformation $(x^\mu, p_\mu) \rightarrow (q^\alpha, J_\alpha)$ to **generalized action-angle** variables [Schmidt 2002; Hinderer & Flanagan 2008]

$$\frac{dJ_\alpha}{d\tau} = -\frac{\partial \bar{H}}{\partial q^\alpha} = 0, \quad \frac{dq^\alpha}{d\tau} = \frac{\partial \bar{H}}{\partial J_\alpha} \equiv \omega^\alpha$$

Particle Hamiltonian first law

- Geodesic motion of **test mass** m in Kerr geometry $\bar{g}_{\alpha\beta}$ derives from **Hamiltonian**

$$\bar{H}(x, p) = \frac{1}{2} \bar{g}^{\alpha\beta}(x^\mu) p_\alpha p_\beta$$

- Hamilton-Jacobi equation is completely separable [Carter 1968]
- Canonical transformation $(x^\mu, p_\mu) \rightarrow (q^\alpha, J_\alpha)$ to **generalized action-angle** variables [Schmidt 2002; Hinderer & Flanagan 2008]

$$\frac{dJ_\alpha}{d\tau} = -\frac{\partial \bar{H}}{\partial q^\alpha} = 0, \quad \frac{dq^\alpha}{d\tau} = \frac{\partial \bar{H}}{\partial J_\alpha} \equiv \omega^\alpha$$

- Varying $\bar{H}(J_\alpha)$ yields a particle Hamiltonian first law valid for **generic** bound orbits [Le Tiec 2014]

$$\delta E = \Omega_\phi \delta L + \Omega_r \delta J_r + \Omega_\theta \delta J_\theta + \langle z \rangle \delta m$$

Including conservative self-force effects

[Fujita *et al.* 2017; Blanco & Flanagan 2022]

- Geodesic motion of **self-gravitating mass m** in effective metric $\bar{g}_{\alpha\beta} + h_{\alpha\beta}^R$ derives from Hamiltonian

$$H(x, p; \gamma) = \bar{H}(x, p) + H_{\text{int}}(x, p; \gamma)$$

Including conservative self-force effects

[Fujita *et al.* 2017; Blanco & Flanagan 2022]

- Geodesic motion of **self-gravitating mass m** in effective metric $\bar{g}_{\alpha\beta} + h_{\alpha\beta}^R$ derives from Hamiltonian

$$H(x, p; \gamma) = \bar{H}(x, p) + H_{\text{int}}(x, p; \gamma)$$

- In class of canonical gauges, one can define a *unique* effective Hamiltonian $\mathcal{H}(J) = \bar{H}(J) + \frac{1}{2}\langle H_{\text{int}} \rangle(J)$ yielding a first law valid for *generic* bound orbits:

$$\delta\mathcal{E} = \Omega_\phi \delta\mathcal{L} + \Omega_r \delta\mathcal{J}_r + \Omega_\theta \delta\mathcal{J}_\theta + \langle z \rangle \delta m$$

Including conservative self-force effects

[Fujita *et al.* 2017; Blanco & Flanagan 2022]

- Geodesic motion of **self-gravitating mass** m in effective metric $\bar{g}_{\alpha\beta} + h_{\alpha\beta}^R$ derives from Hamiltonian

$$H(x, p; \gamma) = \bar{H}(x, p) + H_{\text{int}}(x, p; \gamma)$$

- In class of canonical gauges, one can define a *unique* effective Hamiltonian $\mathcal{H}(J) = \bar{H}(J) + \frac{1}{2}\langle H_{\text{int}} \rangle(J)$ yielding a first law valid for *generic* bound orbits:

$$\delta\mathcal{E} = \Omega_\phi \delta\mathcal{L} + \Omega_r \delta\mathcal{J}_r + \Omega_\theta \delta\mathcal{J}_\theta + \langle z \rangle \delta m$$

- The actions \mathcal{J}_α and the averaged redshift $\langle z \rangle$, as functions of $(\Omega_r, \Omega_\theta, \Omega_\phi)$, include **conservative self-force** corrections from the *gauge-invariant* averaged interaction Hamiltonian $\langle H_{\text{int}} \rangle$

Outline

- ① Circular-orbit binaries: geometrical methods
- ② Beyond circular motion: Hamiltonian methods
- ③ Applications of the first law of binary mechanics

Applications of the first laws

- Fix **'ambiguity parameters'** in 4PN two-body equations of motion [Jaranowski & Schäfer 2012; Damour *et al.* 2014; Bernard *et al.* 2016]
- **Inform the 5PN** two-body Hamiltonian in a 'tutti-frutti' method [Bini, Damour & Geralico 2019; 2020]
- Compute GSF contributions to **energy** and **angular momentum** [Le Tiec, Barausse & Buonanno 2012]
- Calculate Schwarzschild and Kerr **ISCO frequency shifts** [Le Tiec *et al.* 2012; Akcay *et al.* 2012; Isoyama *et al.* 2014]
- Test **cosmic censorship conjecture** including GSF effects [Colleoni & Barack 2015; Colleoni *et al.* 2015]
- Calibrate **EOB potentials** in effective Hamiltonian [Barausse *et al.* 2012; Akcay & van de Meent 2016; Bini *et al.* 2016]
- Compare particle **redshift** to black hole **surface gravity** [Zimmerman *et al.* 2016; Le Tiec & Grandclément 2018; Albalat *et al.* 2022]
- Benchmark for calculations of Schwarzschild **IBCO frequency shift** and gravitational **binding energy** [Barack *et al.* 2019; Pound *et al.* 2020]

Applications of the first laws

- Fix 'ambiguity parameters' in 4PN two-body equations of motion [Jaranowski & Schäfer 2012; Damour *et al.* 2014; Bernard *et al.* 2016]
- Inform the 5PN two-body Hamiltonian in a 'tutti-frutti' method [Bini, Damour & Geralico 2019; 2020]
- Compute GSF contributions to energy and angular momentum [Le Tiec, Barausse & Buonanno 2012]
- ✓ Calculate Schwarzschild and Kerr ISCO frequency shifts [Le Tiec *et al.* 2012; Akcay *et al.* 2012; Isoyama *et al.* 2014]
- Test cosmic censorship conjecture including GSF effects [Colleoni & Barack 2015; Colleoni *et al.* 2015]
- Calibrate EOB potentials in effective Hamiltonian [Barausse *et al.* 2012; Akcay & van de Meent 2016; Bini *et al.* 2016]
- Compare particle redshift to black hole surface gravity [Zimmerman *et al.* 2016; Le Tiec & Grandclément 2018; Albalat *et al.* 2022]
- ✓ Benchmark for calculations of Schwarzschild IBCO frequency shift and gravitational binding energy [Barack *et al.* 2019; Pound *et al.* 2020]

Innermost stable circular orbit (ISCO)

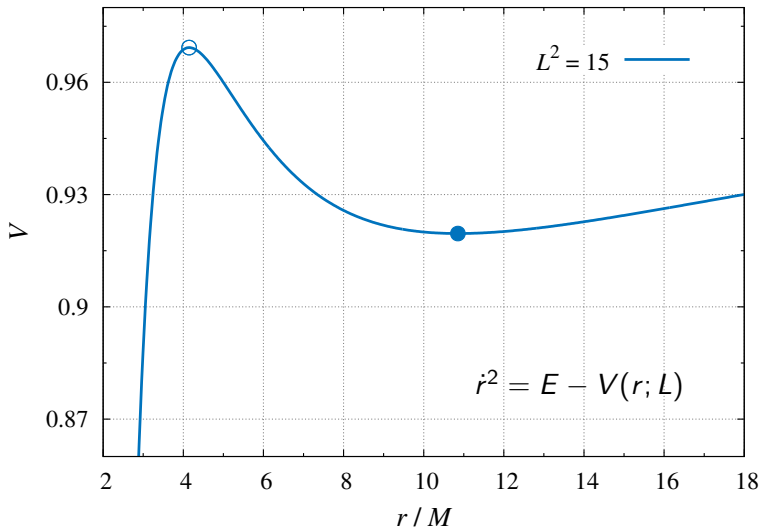

Innermost stable circular orbit (ISCO)

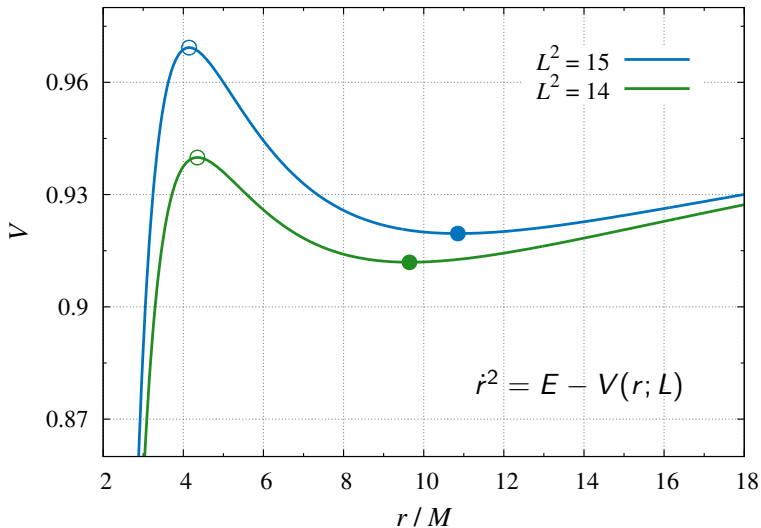

Innermost stable circular orbit (ISCO)

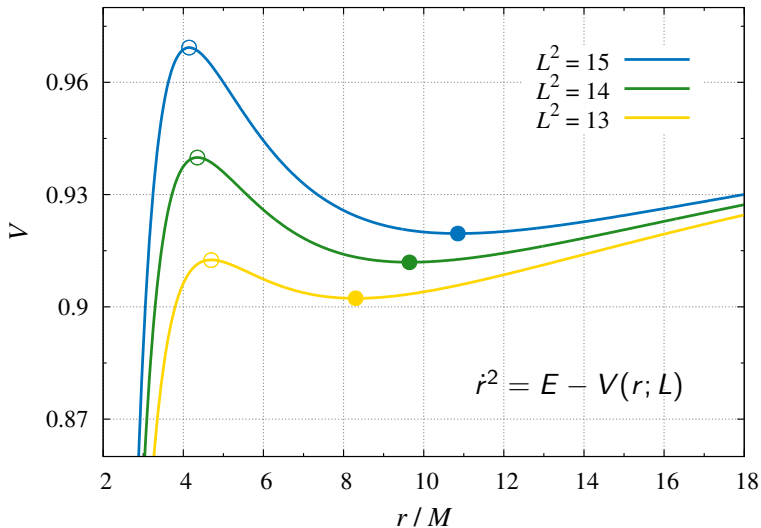

Innermost stable circular orbit (ISCO)

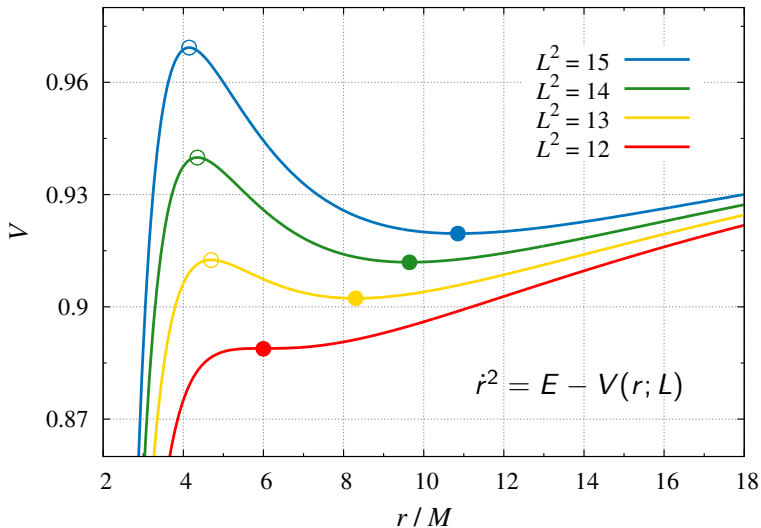

Frequency shift of the Kerr ISCO

[Isoyama, Barack, Dolan, Le Tiec *et al.* 2014]

- The orbital frequency of the Kerr ISCO is shifted under the effect of the **conservative self-force**:

$$(M + \mu)\Omega_{\text{isco}} = \underbrace{M\Omega_{\text{isco}}^{(0)}(\chi)}_{\text{test mass result}} \left[1 + \underbrace{q C_{\Omega}(\chi)}_{\text{self-force correction}} + O(q^2) \right]$$

Frequency shift of the Kerr ISCO

[Isoyama, Barack, Dolan, Le Tiec *et al.* 2014]

- The orbital frequency of the Kerr ISCO is shifted under the effect of the **conservative self-force**:

$$(M + \mu)\Omega_{\text{isco}} = \underbrace{M\Omega_{\text{isco}}^{(0)}(\chi)}_{\text{test mass result}} \left[1 + \underbrace{q C_{\Omega}(\chi)}_{\text{self-force correction}} + O(q^2) \right]$$

- The frequency shift can be computed from a **stability analysis** of slightly eccentric orbits near the Kerr ISCO

Frequency shift of the Kerr ISCO

[Isoyama, Barack, Dolan, Le Tiec *et al.* 2014]

- The orbital frequency of the Kerr ISCO is shifted under the effect of the **conservative self-force**:

$$(M + \mu)\Omega_{\text{isco}} = \underbrace{M\Omega_{\text{isco}}^{(0)}(\chi)}_{\text{test mass result}} \left[1 + \underbrace{q C_{\Omega}(\chi)}_{\text{self-force correction}} + O(q^2) \right]$$

- The frequency shift can be computed from a **stability analysis** of slightly eccentric orbits near the Kerr ISCO
- Combining the **Hamiltonian first law** with the condition $\partial E / \partial \Omega = 0$ yields the same result:

$$C_{\Omega} = 1 + \frac{1}{2} \frac{z''_{(1)}(\Omega_{\text{isco}}^{(0)})}{\hat{E}''_{(0)}(\Omega_{\text{isco}}^{(0)})}$$

ISCO frequency shift vs black hole spin

[Isoyama, Barack, Dolan, Le Tiec *et al.* 2014]

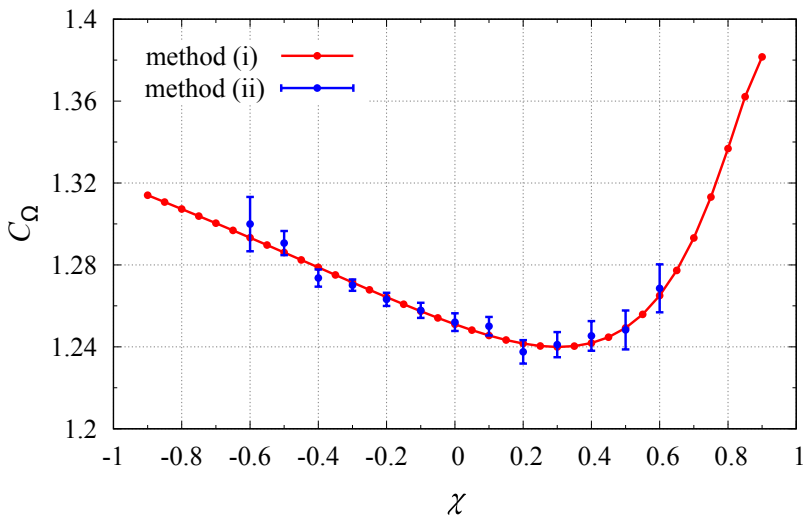

ISCO frequency shift vs black hole spin

[van de Meent 2017]

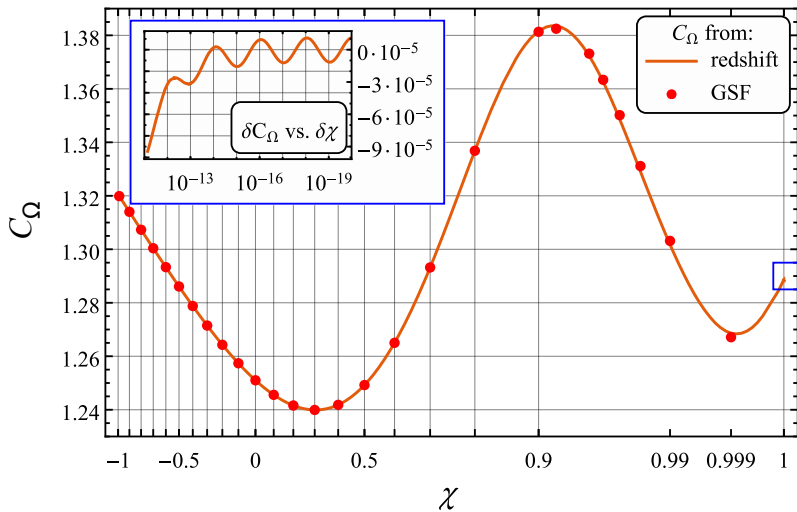

Innermost bound orbit in Schwarzschild

[Barack, Colleoni, Damour, Isoyama & Sago 2019]

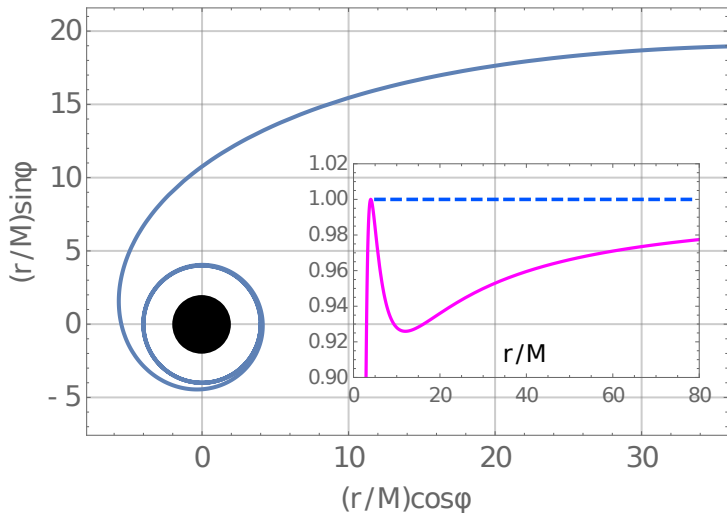

IBCO frequency shift in Schwarzschild

[Barack, Colleoni, Damour, Isoyama & Sago 2019]

Direct self-force calculation

$$\Omega_{\text{IBCO}} = (8M)^{-1} [1 + 0.5536(2) q + O(q^2)]$$

$$J_{\text{IBCO}} = 4M\mu [1 - 0.304(3) q + O(q^2)]$$

First-law prediction

$$\Omega_{\text{IBCO}} = (8M)^{-1} [1 + 0.55360302918(2) q + O(q^2)]$$

$$J_{\text{IBCO}} = 4M\mu [1 - 0.304674287863142(6) q + O(q^2)]$$

Second-order self-force program

- *Second-order gravitational self-force*
A. Pound, PRL **109** (2012) 051101
- *Practical, covariant puncture for second-order self-force calculations*
A. Pound & J. Miller, PRD **89** (2014) 104020
- *Second-order perturbation theory: Problems on large scales*
A. Pound, PRD **92** (2015) 104047
- *Second-order perturbation theory: The problem of infinite mode coupling*
J. Miller, B. Wardell & A. Pound, PRD **94** (2016) 104018
- *Nonlinear gravitational self-force: Second-order equation of motion*
A. Pound, PRD **95** (2017) 104056
- *Second-order self-force calculation of gravitational binding energy in compact binaries*
A. Pound, B. Wardell, N. Warburton & J. Miller, PRL **124** (2019) 021101
- *Two-timescale evolution of extreme-mass-ratio inspirals: Waveform generation scheme for quasicircular orbits in Schwarzschild spacetime*
J. Miller & A. Pound, PRD **103** (2021) 064048
- *Gravitational-wave energy flux for compact binaries through second order in the mass ratio*
N. Warburton, A. Pound, B. Wardell *et al.*, PRL **127** (2021) 151102

Second-order self-force program

- *Second-order gravitational self-force*
A. Pound, PRL **109** (2012) 051101
- *Practical, covariant puncture for second-order self-force calculations*
A. Pound & J. Miller, PRD **89** (2014) 104020
- *Second-order perturbation theory: Problems on large scales*
A. Pound, PRD **92** (2015) 104047
- *Second-order perturbation theory: The problem of infinite mode coupling*
J. Miller, B. Wardell & A. Pound, PRD **94** (2016) 104018
- *Nonlinear gravitational self-force: Second-order equation of motion*
A. Pound, PRD **95** (2017) 104056
- *Second-order self-force calculation of gravitational binding energy in compact binaries*
A. Pound, B. Wardell, N. Warburton & J. Miller, PRL **124** (2019) 021101
- *Two-timescale evolution of extreme-mass-ratio inspirals: Waveform generation scheme for quasicircular orbits in Schwarzschild spacetime*
J. Miller & A. Pound, PRD **103** (2021) 064048
- *Gravitational-wave energy flux for compact binaries through second order in the mass ratio*
N. Warburton, A. Pound, B. Wardell *et al.*, PRL **127** (2021) 151102

Binding energy vs orbital frequency

[Pound, Wardell, Warburton & Miller 2020]

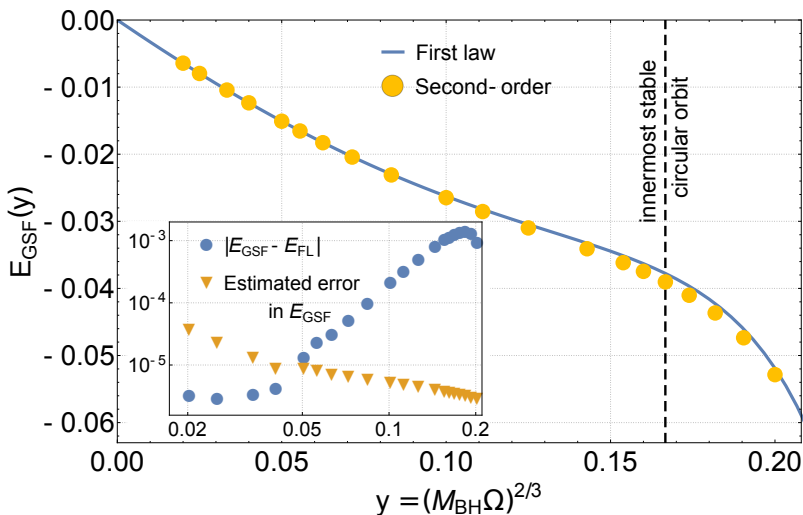

Flux of energy vs orbital frequency

[Warburton, Pound, Wardell, Miller & Durkan 2021]

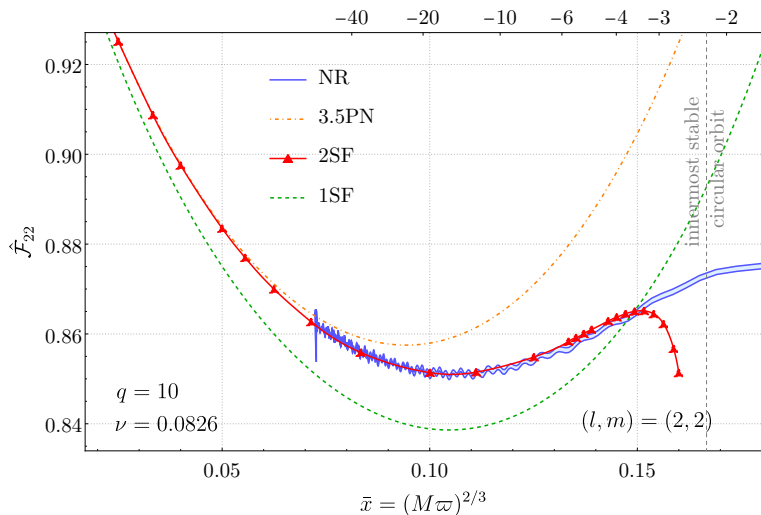

Orbital evolution *via* energy balance

[Bondi *et al.* 1962; Sachs 1962]

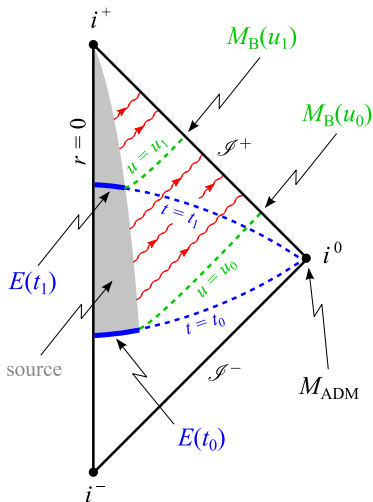

- Bondi mass-loss formula

$$\frac{dM_B}{du} = -\mathcal{F}(u)$$

- Gravitational binding energy

$$E \equiv M_B - M_{\text{BH}} - \mu$$

- Orbital frequency evolution

$$\frac{d\omega}{dt} = -\frac{\mathcal{F}(\omega)}{E'(\omega)}$$

Gravitational waveforms

[Wardell, Pound, Warburton, Miller, Durkan & Le Tiec 2022]

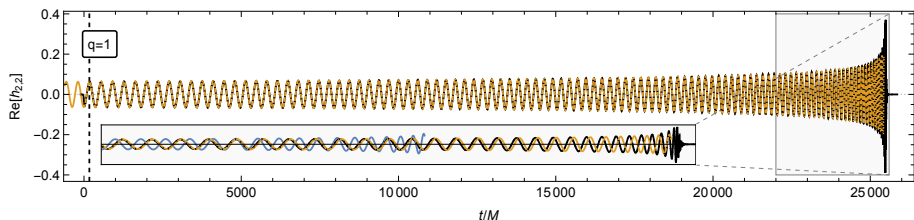
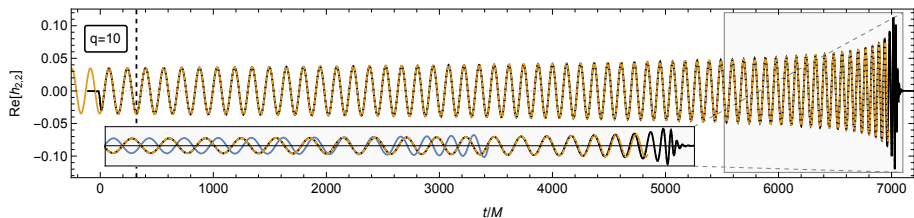

Mode waveform amplitudes

[Wardell, Pound, Warburton, Miller, Durkan & Le Tiec 2022]

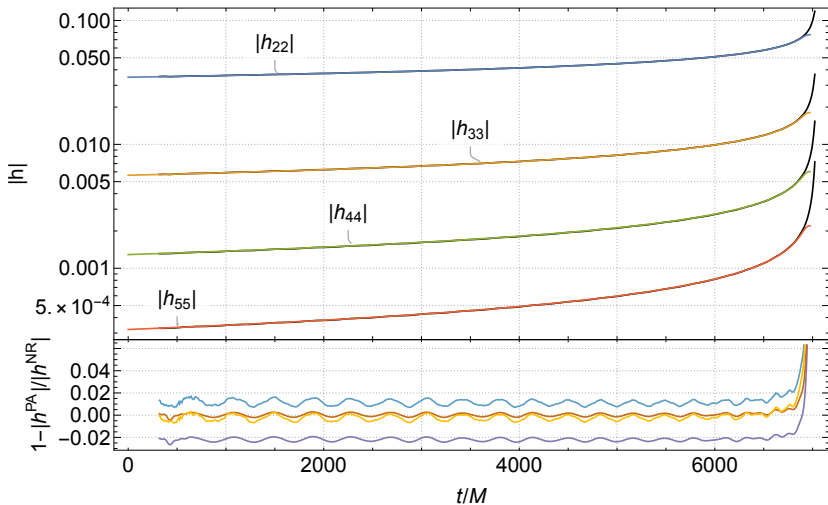

Waveforms frequency evolution

[Wardell, Pound, Warburton, Miller, Durkan & Le Tiec 2022]

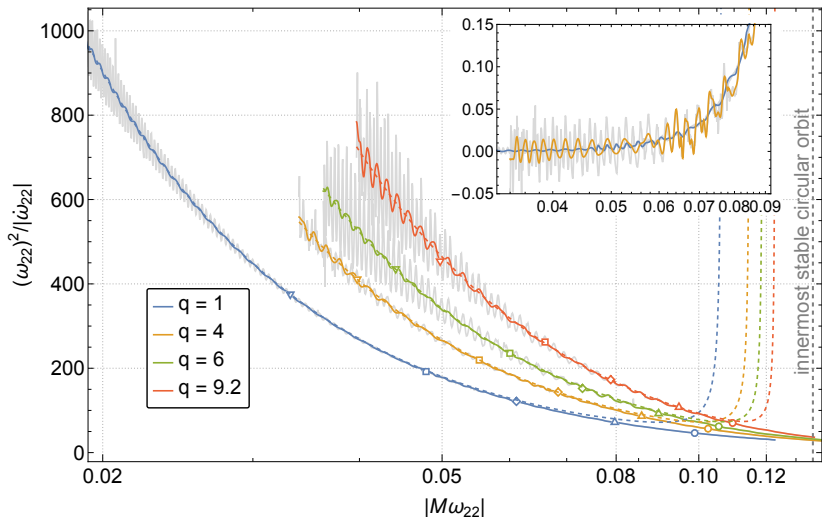

Accumulated dephasing

[Wardell, Pound, Warburton, Miller, Durkan & Le Tiec 2022]

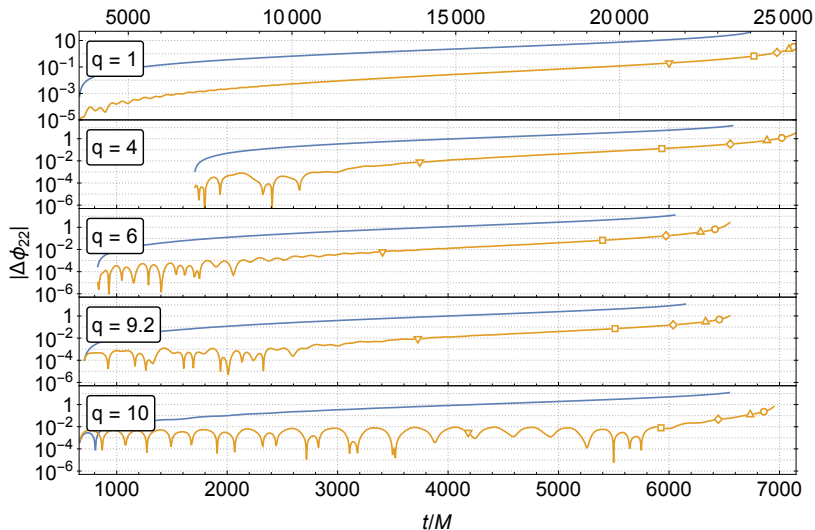

Perturbation theory for comparable masses

$$q \equiv \frac{m_1}{m_2} \rightarrow \nu \equiv \frac{m_1 m_2}{m^2}$$

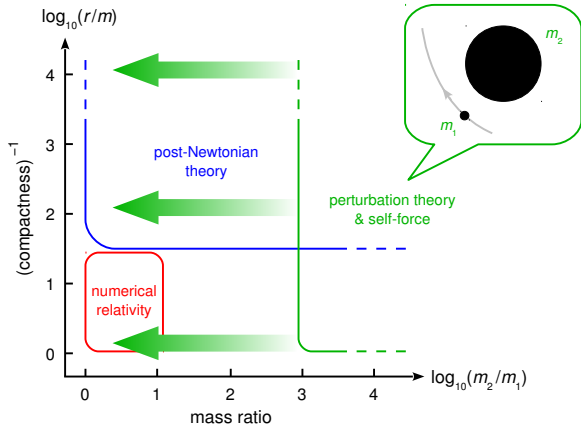

Summary

- The classical laws of black hole mechanics can be extended to **binary systems** of compact objects
- **First laws** of mechanics come in a **variety** of different forms:
 - Context: exact GR, self-force theory, PN theory
 - Objects: black holes, multipolar point particles
 - Orbits: corotating, circular, eccentric, generic
 - Derivation: geometric, Hamiltonian
- Combined with the first law, the **redshift $z(\Omega)$** provides crucial information about the binary dynamics:
 - Gravitational binding energy E and angular momentum J
 - ISCO frequency Ω_{ISCO} and IBCO frequency Ω_{IBCO}
 - EOB effective potentials A, \bar{D}, Q, \dots
 - Horizon surface gravity κ

Prospects

- Small-mass-ratio approximation useful to build templates for **IMRIs** and even **comparable-mass** binaries
- Exploit the Hamiltonian first law for a particle in Kerr:
 - Innermost **spherical** orbits
 - Unbound **zoom-whirl** orbits
- Extend Hamiltonian first law for two spinning particles:
 - **Non-aligned** spins and generic **precessing** orbits
 - Contribution from **quadrupole moments**
- Link to **unbound** orbits and **scattering** angle via analytic continuation?
- Derive a first law in **post-Minkowskian gravity**
- Derive a first law with **dissipation**

Additional Material

Generalized first law of mechanics

[Friedman, Uryū & Shibata 2002]

- Spacetimes with **black holes + perfect fluid** matter sources
- One-parameter family of solutions $\{g_{\alpha\beta}(\lambda), u^\alpha(\lambda), \rho(\lambda), s(\lambda)\}$
- *Globally* defined **Killing field** $k^\alpha \rightarrow$ conserved Noether **charge** Q

$$\delta Q = \sum_i \frac{\kappa_i}{8\pi} \delta A_i + \int_\Sigma [\bar{h} \delta(dM_b) + \bar{T} \delta(dS) + v^\alpha \delta(dC_\alpha)]$$

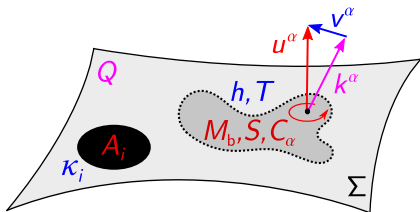

Issue of asymptotic flatness

[Friedman, Uryū & Shibata 2002]

- Binaries on **circular orbits** have a *helical* Killing symmetry k^α
- Helically symmetric spacetimes are *not* asymptotically flat
[Gibbons & Stewart 1983, Detweiler 1989, Klein 2004]
- Asymptotic flatness can be recovered if **radiation** (reaction) can be “**turned off**”:
 - Conformal Flatness Condition
 - Post-Newtonian approximation
 - Black hole perturbation theory
- For **asymptotically flat** spacetimes:

$$k^\alpha \rightarrow t^\alpha + \Omega \phi^\alpha \quad \text{and} \quad \delta Q = \delta M_{\text{ADM}} - \Omega \delta J$$

Application to black hole binaries

[Friedman, Uryū & Shibata 2002]

- Rigidity theorem \rightarrow black holes are in a state of **corotation**
- Conformal flatness condition \rightarrow **asymptotic flatness** recovered
 \hookrightarrow preferred normalization of κ_i [Le Tiec & Grandclément 2018]
- For binary black holes the generalized first law reduces to

$$\delta M_{\text{ADM}} = \Omega \delta J + \sum_i \frac{\kappa_i}{8\pi} \delta A_i$$

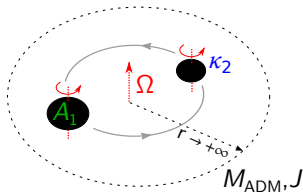

First law for point-particle binaries

[Le Tiec, Blanchet & Whiting 2012]

- For balls of dust, the generalized first law reduces to

$$\delta Q = \int_{\Sigma} z \delta(dM_b) + \dots, \quad \text{where } z = -k^\alpha u_\alpha$$

- Conservative PN dynamics \rightarrow asymptotic flatness recovered
- Two *spinless* compact objects modelled as point masses m_i and moving along circular orbits obey the first law

$$\delta M_{\text{ADM}} = \Omega \delta J + \sum_i z_i \delta m_i$$

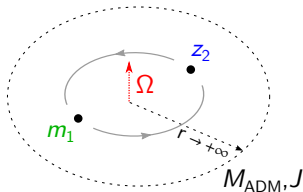

Extension to spinning binaries

[Blanchet, Buonanno & Le Tiec 2013]

- Canonical ADM Hamiltonian $H(x_i, p_i, S_i; m_i)$ of two point particles with masses m_i and spins S_i [Steinhoff *et al.* 2008]
- Redshift observables and spin precession frequencies:

$$\frac{\partial H}{\partial m_i} = z_i \quad \text{and} \quad \frac{\partial H}{\partial S_i} = \Omega_i$$

- First law for aligned spins ($J = L + \sum_i S_i$) and **circular orbits**:

$$\delta M = \Omega \delta L + \sum_i (z_i \delta m_i + \Omega_i \delta S_i)$$

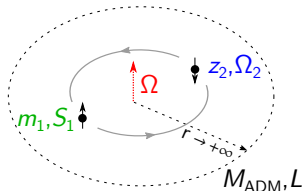

Corotating point particles

[Blanchet, Buonanno & Le Tiec 2013]

- A point particle with rest mass m_i and spin S_i is given an *irreducible* mass μ_i and a proper rotation frequency ω_i via

$$\delta m_i = \omega_i \delta S_i + c_i \delta \mu_i \quad \text{and} \quad m_i^2 = \mu_i^2 + S_i^2 / (4\mu_i^2)$$

- The first law of binary point-particle mechanics becomes

$$\delta M = \Omega \delta J + \sum_i [z_i c_i \delta \mu_i + (z_i \omega_i + \Omega_i - \Omega) \delta S_i]$$

- Comparing with the first law for *corotating* black holes, $\delta M = \Omega \delta J + \sum_i (4\mu_i \kappa_i) \delta \mu_i$, the corotation condition is

$$z_i \omega_i = \Omega - \Omega_i \quad \longrightarrow \quad \omega_i(\Omega) \quad \longrightarrow \quad S_i(\Omega)$$

Surface gravity and redshift

[Blanchet, Buonanno & Le Tiec 2013]

- First law for corotating black holes

$$\delta M = \Omega \delta J + \sum_i (4\mu_i \kappa_i) \delta \mu_i$$

- First law for corotating point particles

$$\delta M = \Omega \delta J + \sum_i z_i c_i \delta \mu_i$$

- Analogy between BH surface gravity and particle redshift

$$4\mu_i \kappa_i \longleftrightarrow z_i c_i$$

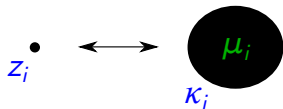

- New *invariant* relations for NR/BHP/PN comparison: $\kappa_i(\Omega)$

Redshift vs orbital frequency

[Zimmerman, Lewis & Pfeiffer 2016]

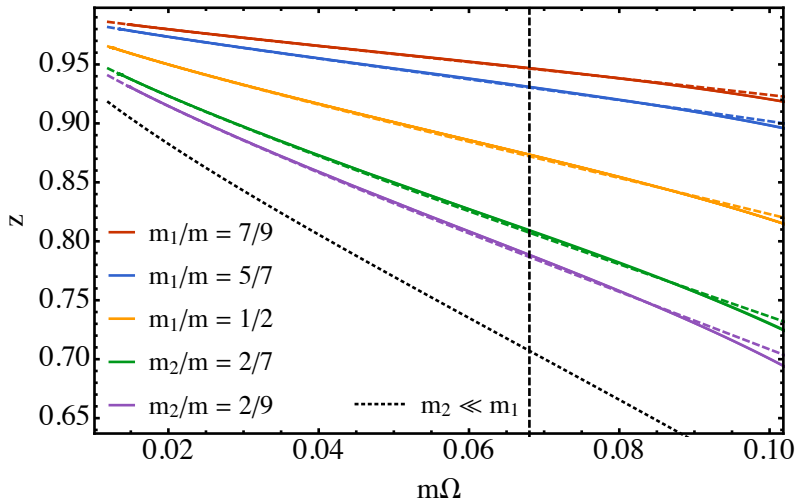

Redshift vs orbital frequency

[Zimmerman, Lewis & Pfeiffer 2016]

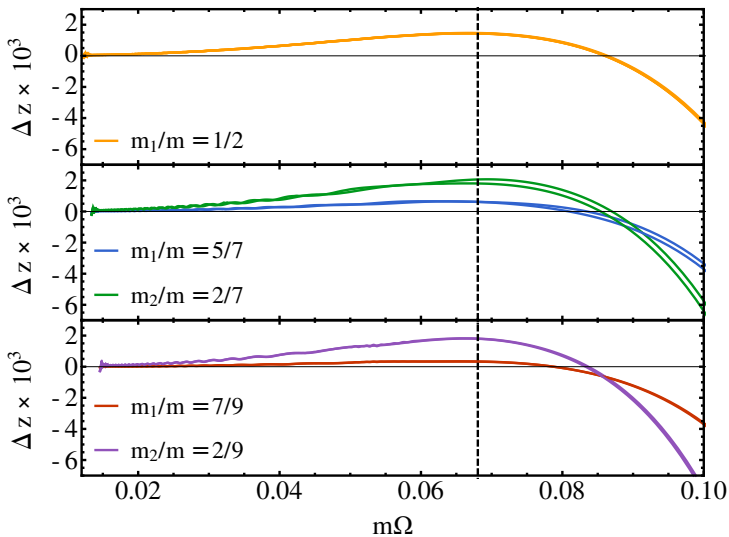

Quasi-equilibrium initial data

- 3+1 decomposition of the metric:

$$ds^2 = -N^2 dt^2 + \gamma_{ij} (dx^i + N^i dt) (dx^j + N^j dt)$$

- Conformal flatness condition approximation:

$$\gamma_{ij} = \psi^4 f_{ij} + h_{ij}$$

- Assume *exact* helical Killing symmetry:

$$\mathcal{L}_k g_{\alpha\beta} = 0 \quad \text{with} \quad k^\alpha = (\partial_t)^\alpha + \Omega (\partial_\phi)^\alpha$$

- Solve five elliptic equations for (N, N^i, ψ)
- Determine orbital frequency Ω by imposing

$$M_{\text{ADM}} = M_{\text{Komar}}$$

- Impose vanishing linear momentum to find rotation axis

Surface gravity for mass ratio 2 : 1

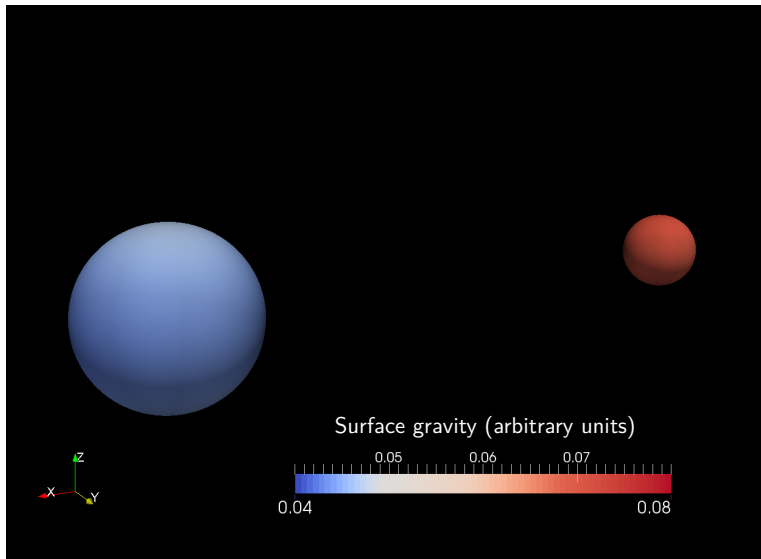

Surface gravity for mass ratio 2 : 1

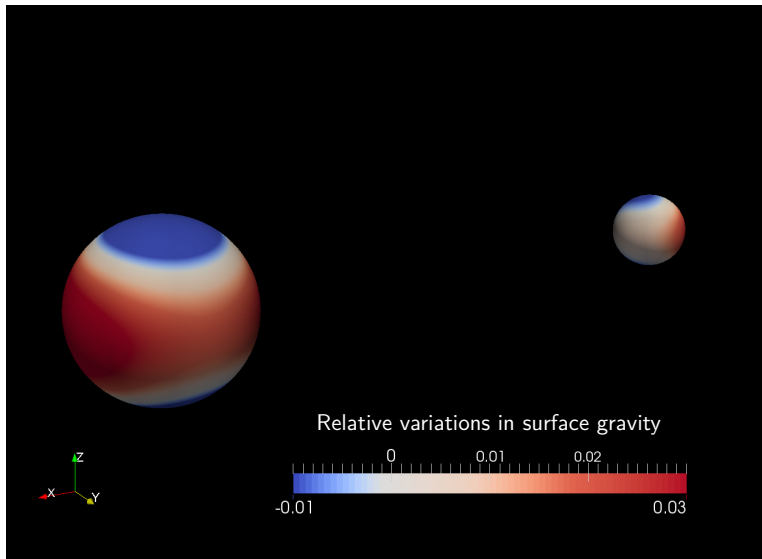

Variations in horizon surface gravity

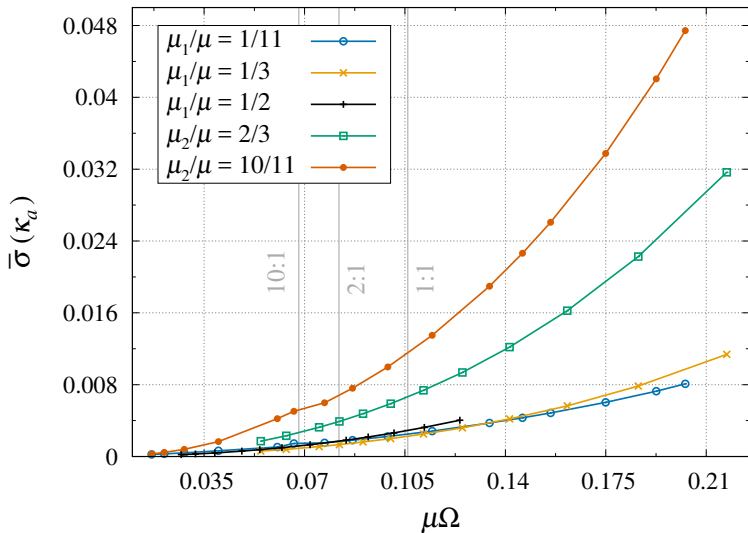

Rotating black hole + orbiting moon

- Kerr black hole of mass M and spin S perturbed by a moon of mass $m \ll M$:

$$g_{ab}(\varepsilon) = \bar{g}_{ab} + \varepsilon \mathcal{D}g_{ab} + \mathcal{O}(\varepsilon^2)$$

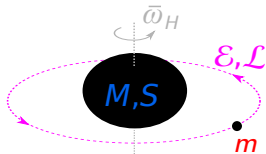

- Perturbation $\mathcal{D}g_{ab}$ obeys the linearized Einstein equation with point-particle source

$$\mathcal{D}G_{ab} = 8\pi \mathcal{D}T_{ab} = 8\pi m \int_{\gamma} d\tau \delta_4(x, y) u_a u_b$$

- Particle has energy $\mathcal{E} = -m t^a u_a$ and ang. mom. $\mathcal{L} = m \phi^a u_a$
- Physical $\mathcal{D}g_{ab}$: retarded solution, no incoming radiation, perturbations $\mathcal{D}M_B = \mathcal{E}$ and $\mathcal{D}J = \mathcal{L}$ [Keidl et al. 2010]

Rotating black hole + corotating moon

- We choose for the **geodesic** γ the unique equatorial, circular orbit with azimuthal frequency $\bar{\omega}_H$, i.e., the *corotating* orbit
- Gravitational radiation-reaction is $\mathcal{O}(\varepsilon^2)$ and neglected
The spacetime geometry has a **helical symmetry**
- In adapted coordinates, the helical Killing field reads

$$\chi^a = t^a + \bar{\omega}_H \phi^a$$

- Conserved orbital quantity associated with symmetry:

$$z \equiv -\chi^a u_a = m^{-1} (\mathcal{E} - \bar{\omega}_H \mathcal{L})$$

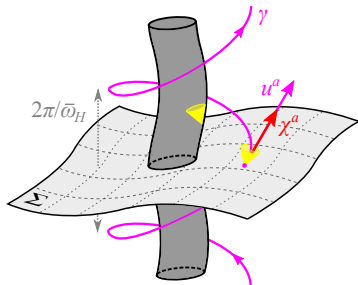

Zeroth law for a black hole with moon

[Gralla & Le Tiec 2013]

- Because of helical symmetry and corotation, the **expansion** and **shear** of the *perturbed* future event horizon H vanish
- Rigidity theorems then imply that H is a **Killing horizon**
[Hawking 1972, Chruściel 1997, Friedrich *et al.* 1999, etc]
- The horizon-generating **Killing field** must be of the form

$$k^a(\varepsilon) = t^a + \underbrace{(\bar{\omega}_H + \varepsilon \mathcal{D}\omega_H)}_{\substack{\text{circular orbit} \\ \text{frequency } \Omega}} \phi^a + \mathcal{O}(\varepsilon^2)$$

- The **surface gravity** κ is defined in the usual manner as

$$\kappa^2 = -\frac{1}{2} (\nabla^a k^b \nabla_a k_b)|_H$$

- Since $\kappa = \text{const.}$ over *any* Killing horizon [Bardeen *et al.* 1973], we have proven a **zeroth law** for the *perturbed* event horizon

Angular velocity vs black hole spin

[Gralla & Le Tiec 2013]

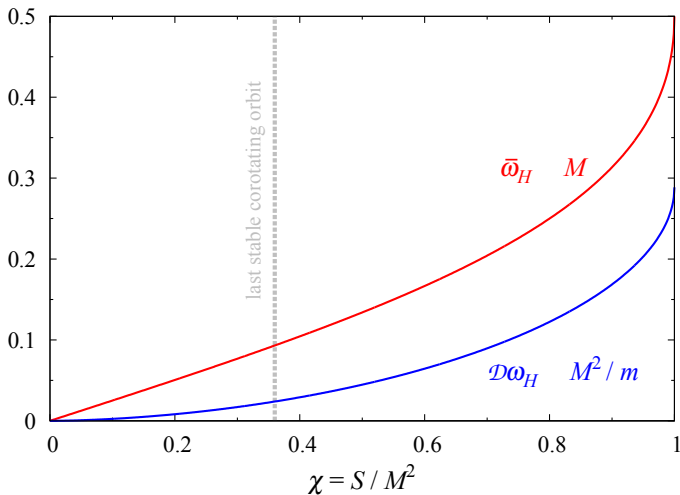

Surface gravity vs black hole spin

[Gralla & Le Tiec 2013]

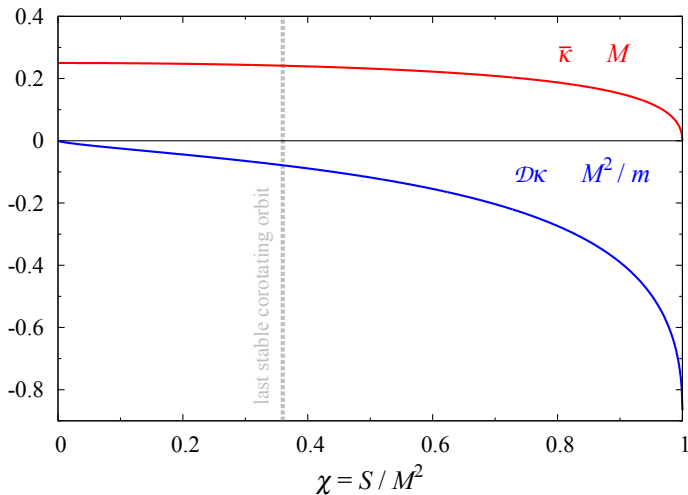

First law for a black hole with moon

[Gralla & Le Tiec 2013]

- Adapting [Iyer & Wald 1994] to **non-vacuum** perturbations of **non-stationary** spacetimes we find (with $Q_{ab} \equiv -\varepsilon_{abcd} \nabla^c k^d$)

$$\int_{\partial\Sigma} (\delta Q_{ab} - \Theta_{abc} k^c) = 2 \delta \int_{\Sigma} \varepsilon_{abcd} G^{de} k_e - \int_{\Sigma} \varepsilon_{abcd} k^d G^{ef} \delta g_{ef}$$

- Applied to nearby BH with moon spacetimes, this gives the first law

$$\delta M_B = \Omega \delta J + \frac{\kappa}{8\pi} \delta A + z \delta m$$

- Features variations of the **Bondi** mass and angular momentum

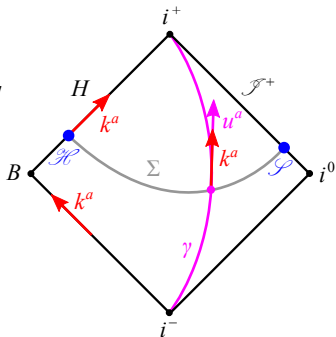

Binding energy vs angular momentum

[Le Tiec, Barausse & Buonanno 2012]

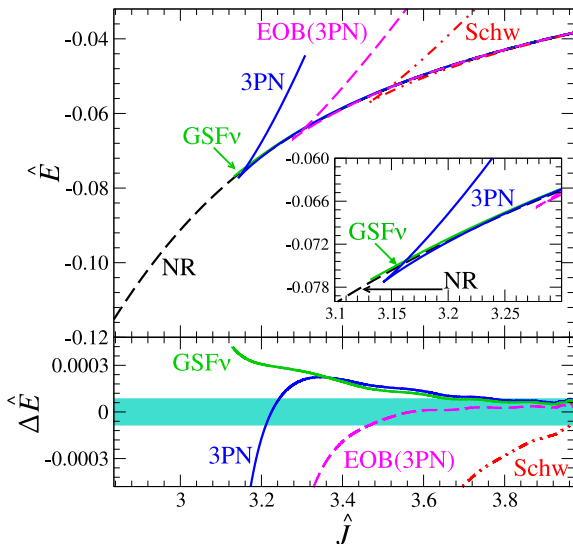

Why does BHPT perform so well?

- In perturbation theory, one traditionally expands as

$$f(\Omega; m_i) = \sum_{k=0}^{k_{\max}} a_k(m_2 \Omega) q^k \quad \text{where} \quad q \equiv m_1/m_2 \in [0, 1]$$

- However, most physically interesting relationships $f(\Omega; m_i)$ are **symmetric** under exchange $m_1 \longleftrightarrow m_2$
- Hence, a better-motivated expansion is

$$f(\Omega; m_i) = \sum_{k=0}^{k_{\max}} b_k(m \Omega) \nu^k \quad \text{where} \quad \nu \equiv m_1 m_2 / m^2 \in [0, 1/4]$$

- In a PN expansion, we have $b_n = \mathcal{O}(1/c^{2n}) = n\text{PN} + \dots$

Why does BHPT perform so well?

- In perturbation theory, each surface gravity is expanded as

$$4\mu_1\kappa_1 = a(\mu_2\Omega) + q b(\mu_2\Omega) + \mathcal{O}(q^2)$$

$$4\mu_2\kappa_2 = c(\mu_2\Omega) + q d(\mu_2\Omega) + \mathcal{O}(q^2)$$

- From the first law we know that the general form is

$$4\mu_i\kappa_i = \sum_{k \geq 0} \nu^k f_k(\mu\Omega) \pm \sqrt{1 - 4\nu} \sum_{k \geq 0} \nu^k g_k(\mu\Omega)$$

- Each surface gravity can thus be rewritten as

$$4\mu_i\kappa_i = A(\mu\Omega) \pm B(\mu\Omega) \sqrt{1 - 4\nu} + C(\mu\Omega) \nu \\ \pm D(\mu\Omega) \nu \sqrt{1 - 4\nu} + \mathcal{O}(\nu^2)$$

- Expand to linear order in q and match $\rightarrow A, B, C, D$

EOB dynamics beyond circular motion

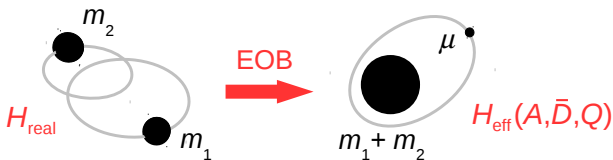

- Conservative EOB dynamics determined by “potentials”

$$A(r) = 1 - 2M/r + \nu a(r) + \dots$$

$$\bar{D}(r) = 1 + \nu \bar{d}(r) + \dots$$

$$Q(r) = \nu q(r) p_r^4 + \dots$$

- Functions $a(r)$, $\bar{d}(r)$ and $q(r)$ controlled by $\langle z \rangle_{\text{GSF}}(\Omega_r, \Omega_\phi)$

EOB dynamics beyond circular motion

[Akçay & van de Meent 2016]

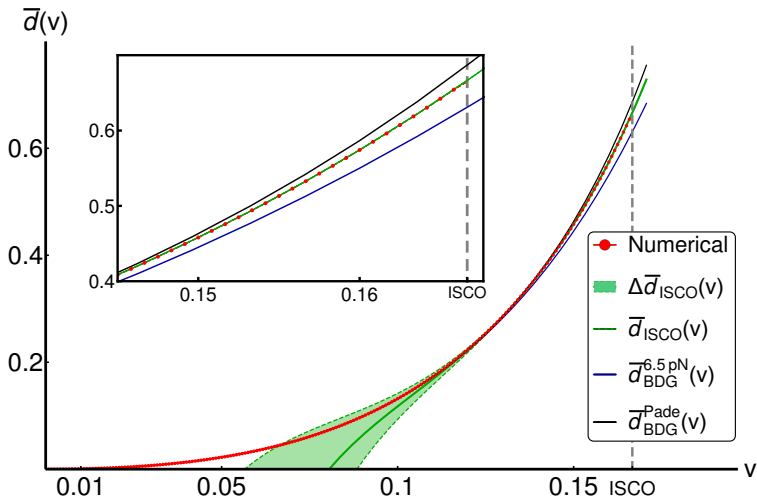

EOB dynamics beyond circular motion

[Akçay & van de Meent 2016]

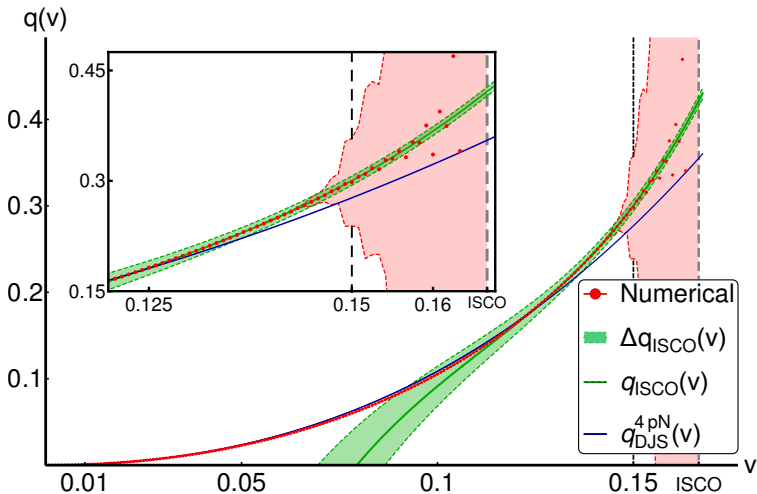

EOB dynamics for spinning bodies

[Bini, Damour & Geralico 2016]

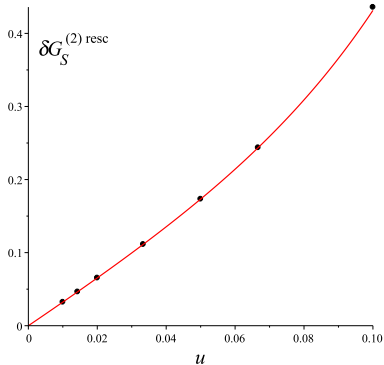
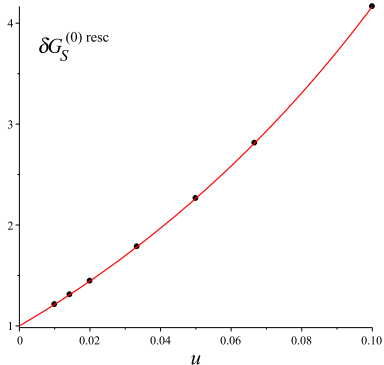

First law for spinning bodies } \implies SO coupling function $\delta G_S(u, \hat{a})$
GSF contribution to redshift }